

Structural Lightweight Aggregate Concrete Performance

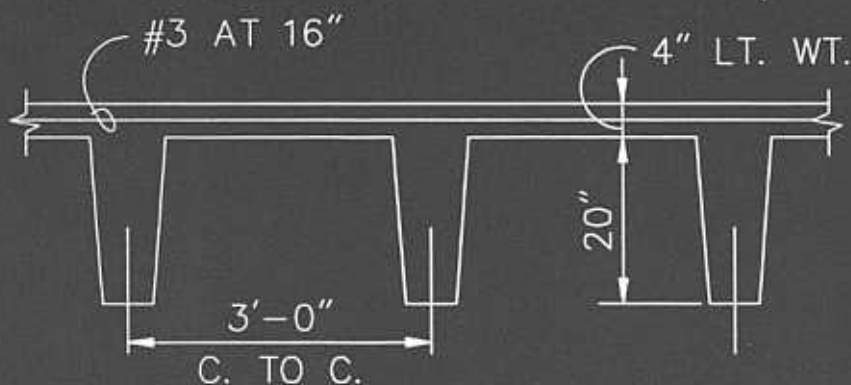
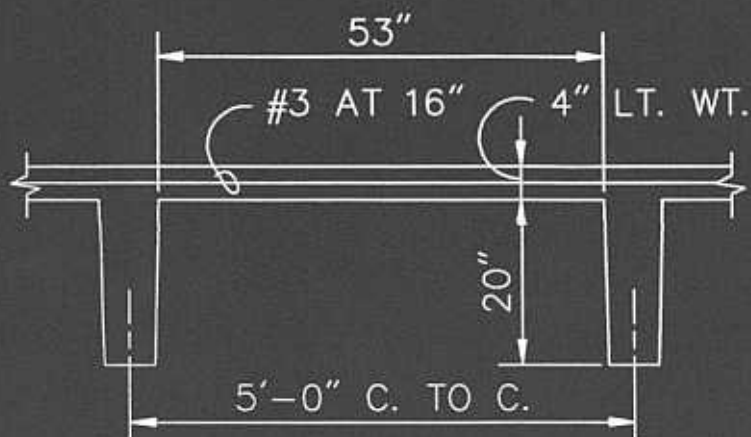

Thomas A. Holm
Alexander M. Vaysburd
Editors

aci SP-136

PREFACE

This volume is a compilation of papers addressing the "Performance of Structural Lightweight Concrete" presented at the November 14, 1991 technical session of the American Concrete Institute fall convention in Dallas, Texas. Planning for this symposium, sponsored by ACI Committee 213, "Structural Lightweight Aggregate," was in response to construction industry and engineering community interest in using structural lightweight concrete in severe environment applications. The immediate need for disseminating state-of-the-art information motivated the development of this two session symposium.

The speakers addressed topics ranging from fundamental laboratory studies to case histories of concrete performance. The papers include application of lightweight concrete for bridges, arctic structures, buildings and parking structures, aspects of structural design, production and durability of lightweight concrete structures.

We thank the authors for sharing their knowledge, and Messrs. John P. Ries and Dr. Theodore W. Bremner for serving as session co-chairmen. A special note of appreciation is directed towards the many session paper reviewers and to the support and constructive suggestions offered by the 213 committee members and their chairman, David Akers.

Thomas A. Holm
Alexander M. Vaysburd
Session Chairmen

CONTENTS

Preface	iii
HIGH STRENGTH LIGHTWEIGHT AGGREGATE CONCRETE FOR ARCTIC APPLICATIONS—PART 1 by G.C. Hoff	1
HIGH STRENGTH LIGHTWEIGHT AGGREGATE CONCRETE FOR ARCTIC APPLICATIONS—PART 2 by G.C. Hoff	67
HIGH STRENGTH LIGHTWEIGHT AGGREGATE CONCRETE FOR ARCTIC APPLICATIONS—PART 3 by G.C. Hoff	175
THE ADVANTAGES OF USING LIGHTWEIGHT CONCRETE IN A MEDIUM RISE BUILDING AND ADJOINING POST-TENSIONED PARKING GARAGE by R. Trumble and L. Santiago	
LIGHTWEIGHT CONCRETE BRIDGES FOR CALIFORNIA HIGHWAY SYSTEM by J.E. Roberts	255
LIGHTWEIGHT MICROSILICA (SILICA FUME) CONCRETE IN THE USA by M.D. Luther	273
DURABILITY OF LIGHTWEIGHT CONCRETE AND ITS CONNECTIONS WITH THE COMPOSITION OF CONCRETE DESIGN AND CONSTRUCTION METHODS by A.M. Vaysburd	
HIGH DUCTILITY, HIGH STRENGTH LIGHTWEIGHT AGGREGATE CONCRETE by D.E. Berner	

INFLUENCE OF COMPRESSIVE STRESS ON THE PERMEABILITY OF CONCRETE by T.W. Bremner, T.A. Holm, and J.M. McInerney . . .	345
FLEXURAL BEHAVIOR INCLUDING DUCTILITY OF HIGH STRENGTH LIGHTWEIGHT CONCRETE MEMBERS UNDER REVERSED CYCLIC LOADING by S.K. Ghosh, D.P. Narielwala, S.W. Shin, and J. Moreno	357
PORE STRUCTURE AND CARBONATION OF LIGHTWEIGHT CONCRETE AFTER 10 YEARS EXPOSURE by R.N. Swamy and E.D. Jiang	377
FATIGUE STRENGTH AND ENDURANCE LIMIT OF LIGHTWEIGHT CONCRETE by V. Ramakrishnan, T.W. Bremner, and V.M. Malhotra	397
SI (metric) TABLES	421
INDEX	423